

WHAT YOU NEED TO APPLY FOR A BUILDING PERMIT:

- Site Plan - Page 2
- Floor Plan - Page 2
- Construction Details - Page 3
- Additional Requirements - Page 4
- Permit Application



DID YOU KNOW?

- ✓ As “owner-builder” you are the responsible party of record on such a permit. If your work is being performed by a contractor, you may protect yourself from possible liability if the contractor applies for the proper permit in his or her name.
- ✓ If you plan to do your own work, including all of the trade work, then you may apply for the permit.
- ✓ NOTICE: The State law requires you to occupy the structure for 2 years after such work has been completed.
- ✓ Frequent practices of unlicensed contractors is to secure “owner-builder” building and trades permits, erroneously implying that the property owner is providing his or her own labor and material personally.
- ✓ It would benefit you to hire a licensed contractor to perform the trade work.
- ✓ Permits are valid for work to begin within six months.

Why Do I need a Permit?

There are many important reasons to obtain building permits and to have inspections performed for your construction project.

Protects property values

Your home is typically your largest investment. If your construction project does not comply with the building codes, your investment could lose value. If others in your neighborhood make unsafe or substandard changes to their homes, it could lower the resale values for the entire community.

Saves Money

Homeowners insurance policies may not pay for damages caused by work done without permits and inspections.

Makes Selling Property Easier

Listing associations require owners to disclose any home improvements or repairs and whether permits were obtained. Many financial institutions will not finance a purchase without proof of a final inspection. If you decide to sell a home or building that has had modifications without a permit, you may be required to tear down the addition, leave it unoccupied or do costly repairs.

Improves safety

Your permit allows the building department to inspect for potential hazards and unsafe construction. By ensuring your project meets the minimum building code standards of safety, the building department can reduce the risk of fire, structural collapse and other issues that might result in costly repairs, injuries and even death. Inspections complement the contractor’s experience and act as a system of checks and balances that can result in a safer project.

It’s the Law

Permits are required by Ordinance. Work without a permit may be subject to removal or other costly remedies.

TIPS ON HIRING CONTRACTORS

- ✓ Hire only licensed contractors.
- ✓ Get at least 3 bids.
- ✓ Get 3 references, and ask to see a project.
- ✓ Get it in writing, but before you sign the contract, make sure you completely understand.
- ✓ Do not make final payment until you have received a Certificate of Occupancy (CO) and until you are satisfied.
- ✓ Have the contractor apply for the required permits.

WHAT IS A SITE PLAN?

A site plan is a detailed drawing of your property, also known as a survey of your land. These are usually drawn by a land surveyor. The site plan will show the dimensions of your project and its relationship to existing setbacks, easements, utilities, other structures on the property, and distance to your property lines. If your project will require moving any utilities (gas, water, sewer/septic, electric, etc.), show where those utilities will be relocated.

What is REQUIRED for a Permit?

- Provide copies of the SITE PLAN

Notes:

1. Structures shall not be permitted to be built over setback lines, easements, or property lines. Check with your local zoning department for any location or size restrictions.
2. A survey from a registered land surveyor will be required if your project is located in a protected area.
3. An as-built survey is required if the structure is proposed within 12 inches of a required minimum setback.
4. If your property is on a slope, you may be required to install silt fence to keep the dirt on your property.
5. If you are on a septic tank, you will be required to have approval from the county health department prior to issuance of a permit.
6. If you do not know the location of your utilities, contact the Utility Notification Center. Remember to ask them about the cost of this service.

Sample site plan
Not to Scale

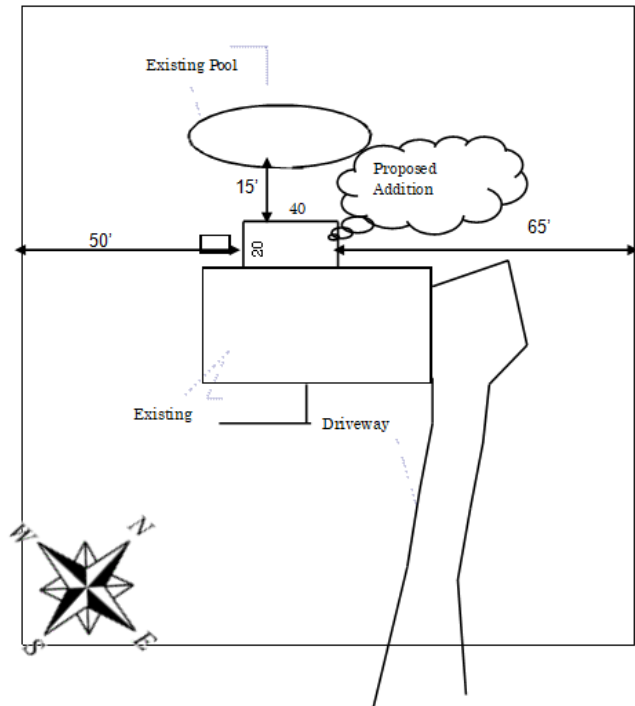

FLOOR PLAN

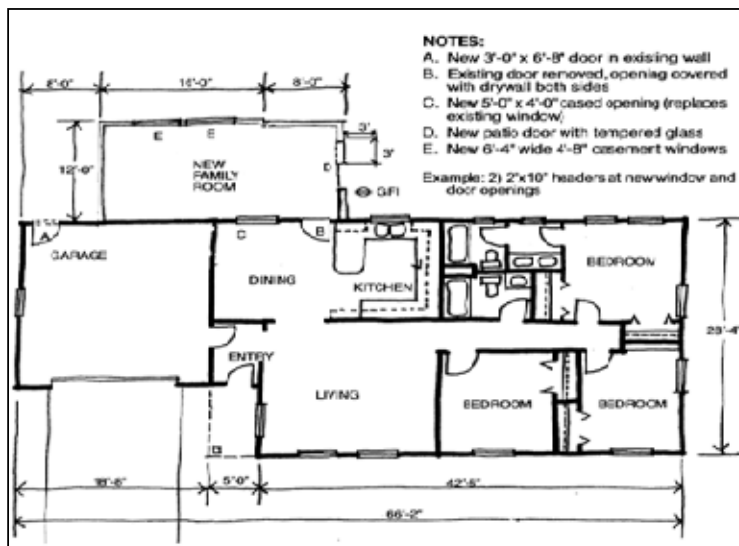

The floor plan is used to determine the complexity of the work and to validate the site plan. Floor plans must show existing dimensions of the house, dimensions of the new room, any new openings and items that will be relocated.

Requirements for a permit:

- Provide copies of the FLOOR PLAN

Notes:

1. When plans show any new openings that exceed 6 feet in a bearing wall, detailed specifications will be required.
2. Additions cannot enclose bedroom or basement egress windows.
3. Heat is required in all habitable rooms. Show how heat will be supplied to the addition.
4. Existing electric service may require an upgrade or relocation. Indicate the size of your existing electric service (AMPS) on your plan.

CONSTRUCTION DETAILS

Construction details and specifications help the building department find problems before they occur in the field.

This example shows the types of detail our office will be looking for in your plan submittal.

In addition to construction details such as these, you will need to submit details on:

1. Foundation detail
2. Exterior elevations
3. Energy Code Compliance Report (energycodes.gov) or REScheck calculations
4. The installation of new HVAC appliances will require Manual D&J documentation.

REMINDER:

Permits are only issued after plan review. The time required to conduct this review will depend on the completeness of the information we receive in the plans.

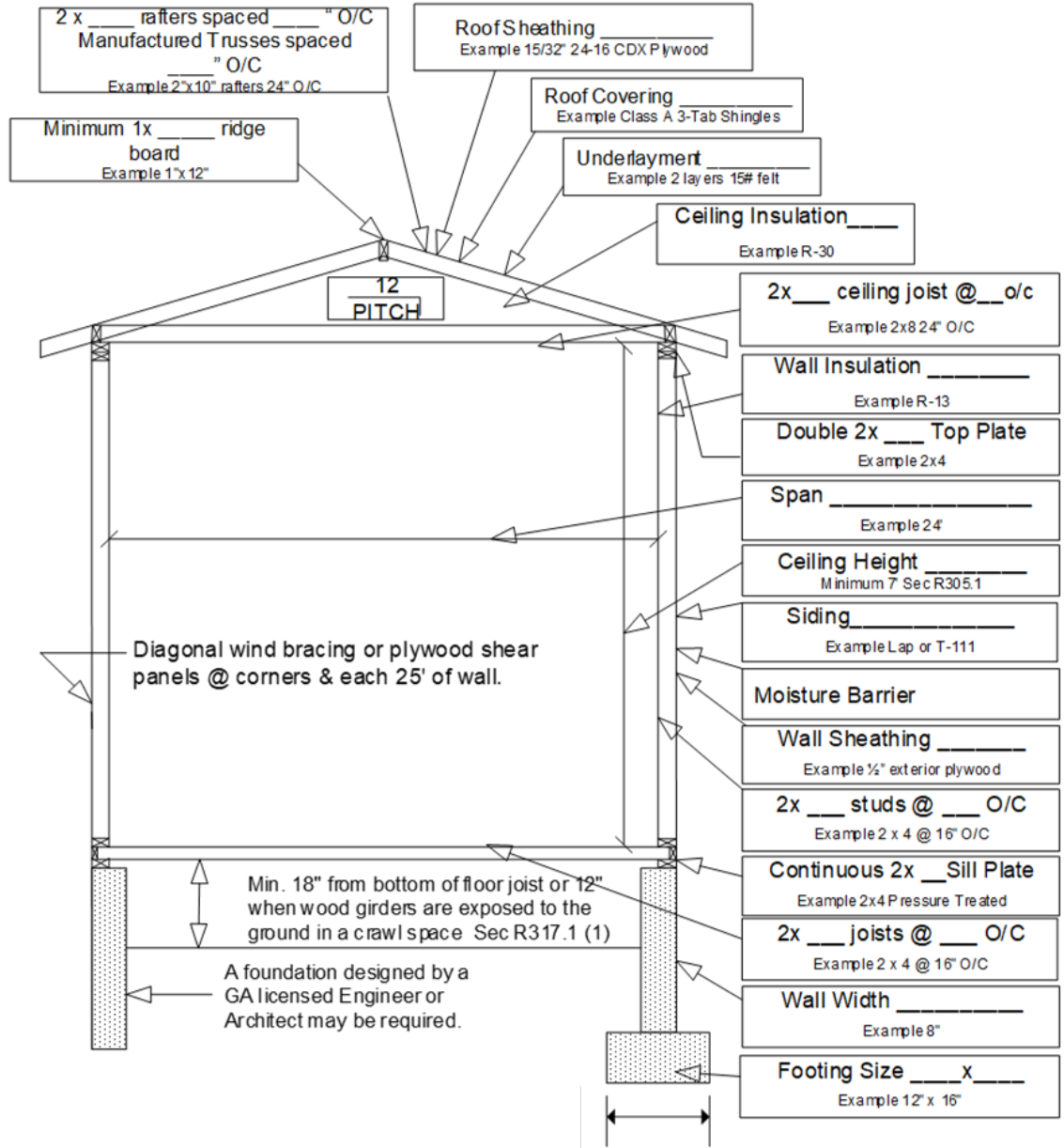

Notes:

- Provide solid 2x blocking between rafters or trusses and roof tie downs.
- Attic ventilation and access is required for spaces 30" or greater in height.
- For roofs with slopes less than a 4:12 pitch, follow manufacturer's instructions for low slope application of roofing material.
- Where new roofs adjoin walls of an existing structure, flashing must be installed under the existing exterior finish material and over the new roof.
- For all pre-engineered systems, the manufacturer's specifications must be available to the inspector on-site. Failure to provide these materials upon request will result in your project failing inspection.

Typical Slab Detail for single story Single Family Dwelling

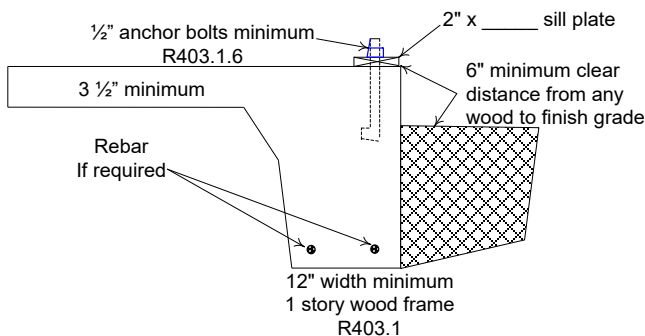

ADDITIONAL INFORMATION

What will the Building Inspector look at?

A typical home addition project will require the following inspections:

1. **Foundation & Foundation Wall** Foundation inspections shall be made after trenches are excavated, reinforcement steel is in place, forms erected, and PRIOR to placing of concrete.
2. **Underground** Inspection shall be made PRIOR to covering of any piping or wiring and prior to placing concrete.
3. **Rough Trade** This inspection is for performed once the plumbing, mechanical and electrical rough installation is complete prior to covering or commissioning. These inspections may be performed with the rough frame inspection.
4. **Rough Frame** Inspection This inspection is made after the roof, all framing, fire stopping, sheathing, draft stopping, bracing and fasteners are in place.
5. **Insulation** Inspection made after insulation in place, PRIOR to covering walls.
6. **Final** Inspection made AFTER the addition is completed.

The permit technician will let you know your projects' required inspections when the permit is issued.

The purpose of this guide is to assist you in the permitting process. This handout is intended to cover information for a basic plan submittal and typical project under the building codes. It is not intended to cover all circumstances. Depending on the scope and complexity of your project, additional information may be required. Discuss your project with city staff to determine if it is subject to additional requirements.

HOW DO I SCHEDULE A REQUIRED INSPECTION?

Please call the inspection line listed on your permit card and leave all information requested in the message.

Want to know more? Need more help?

We hope you found the information in this guide useful. If you have any questions, please feel free to contact us.

CRAWL SPACE FOUNDATION DETAIL

(Additions over basements will require and engineer designed foundation)

